

HIGH COUNTRY STRAIGHT PLOW

SNOW & ICE CONTROL

FEATURES & BENEFITS:

- 1 Deep "C" A-Frame
- 2 (3) Adjustable pitch settings
- 3 5" X 5" x 3/8" hd square tube table with 90" wide push frame, and 3-1/2" round pivot bushing
- 4 (2) Telescopic trip bars, (6) extension trip springs and (4) 3" poly bushings for return trip cushions
- 5 (5) Table moldboard hook-up points with 1/2" reinforced ribs, 3" bearing surface and 1-1/4" pins
- 6 Extended roll moldboard continuously welded
- 7 7" X 4" x 1/2" fully boxed bottom angle

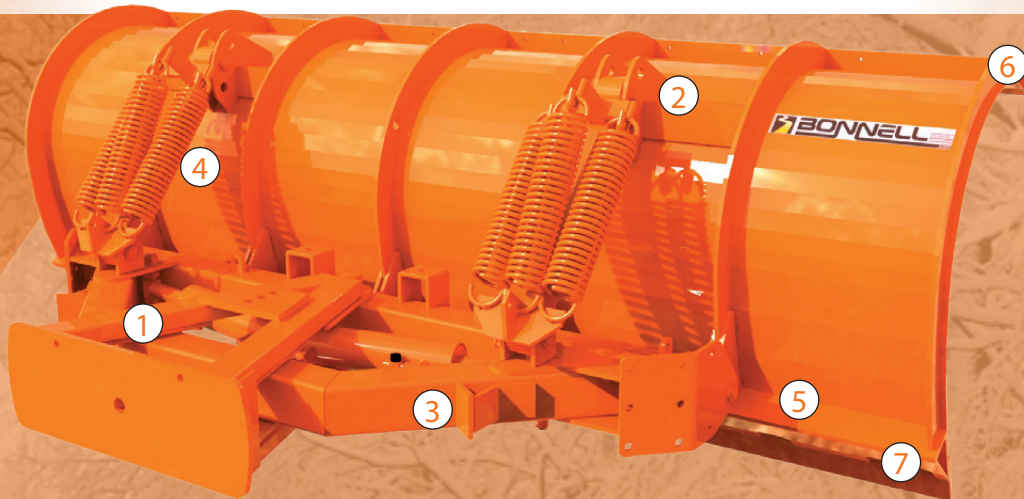

POLY-MOLDBOARD
OPTION



HIGH COUNTRY PLOW OPTIONS

Plow Lift Options

Chain

- Level Raise Lift System
Chain And Saddle
Cable Wrap

Plow Hook-Up Options

- Quick Attach Loop
Swivel Bar With Push Ears
(1- 1/4" Pins @ 30.5")
Husting Style
QL2, UQH, or Other

Moldboard Options

- 3/4" Bottom Angle
7- Gauge Steel Construction
Curb Cut (Mailbox Cut)
Extra Ribs
UHMW Poly Construction

Table Options

Extended Push Frame
Manual Reverse

Running Gear Options

Standard Mushroom Shoes
Heavy-Duty Mushroom Shoes

- Heavy-Duty Even Wear Shoes
Carbide Even Wear Shoes
10" Steel Caster Wheels
5.70" x 8" Pneumatic Tires
Foam-Filled Rubber Tires
Don't use with Cable Wrap Lift Assemblies

Cutting Edge Options

High Carbon Steel
Rubber
UHMW Poly
Carbide Insert with Cover Blade
Flame Hardened

- PolarFlex Systems
All cutting edges available
in various sizes

Other Options

- Cushion Valve
Curb Shoes

Blade Savers- Carbide

Blade Guides

- Rubber Snow Deflector
Plow Stand
Extra Extension Trip Springs

Tripping Options

- Extension Trip Moldboard
Compression Trip Moldboard
Dual Moldboard & Trip Edge
 - Torsion Trip Cutting Edge
Slotted Trip

Paint Options

Special Paint Available



HIGH COUNTRY STRAIGHT PLOW STANDARD SPECIFICATIONS

MODEL NUMBER	LENGTH	HEIGHT	CUTTING SWATH @ 35°	APPROX. WEIGHT OF BASE UNIT	NUMBER OF SPRINGS
10ST36MX1	10'	36"	8'2"	1960 lbs.	4
11ST36MX1	11'	36"	9'	2025 lbs.	4
12ST36MX1	12'	36"	9' 10"	2090 lbs.	4
10ST42MX1	10'	42"	8' 2"	2052 lbs.	6
11ST42MX1	11'	42"	9'	2119 lbs.	6
12ST42MX1	12'	42"	9' 10"	2186 lbs.	6
10ST49MX1	10'	49"	8' 2"	2100 lbs.	6
11ST49MX1	11'	49"	9'	2170 lbs.	6
12ST49MX1	12'	49"	9' 10"	2240 lbs.	6
11ST60MX1	11'	60"	9'	2500 lbs.	8
12ST60MX1	12'	60"	9' 10"	2600 lbs.	8

- Moldboard Thickness: 10 Gauge
- Moldboard Reinforcing: (7) - 1/2" x 3" Ribs
- Adjustable Moldboard Pitch Setting: 35°, 25° or 15° off vertical
- Lower Reinforcing Angle: 7" x 4" x 1/2"
- Reversing Frame: 5" x 3/8" Wall Front Push Tube
- Reversing Cylinders: 4" Bore x 12" Stroke (2" Rod) Double Acting
- Reversing Limits (left & right): 0 to 35 degrees
- Plow to Table Hinge Points: (5) 1-1/4" Hinge Pins, Spanning 90"
- Cutting Edge: 5/8" x 6" High Carbon Steel
- Pivot Pin: 1-1/2" Grade 8 Bolt
- Cylinder Pins: 1-1/4" C1045 Steel Pins

Call factory for complete specifications and optional equipment not listed. Weights do not include optional equipment.



AUTHORIZED DEALER:

www.bonnell.com • (800) 851-9664 • info@bonnell.com
1385 Franklin Grove Rd. • Dixon, IL 61021



HIGH COUNTRY TAPERED PLOW

SNOW & ICE CONTROL

FEATURES & BENEFITS:

- 1 Deep "C" A-Frame
- 2 (3) Adjustable pitch settings
- 3 5" X 5" x 3/8" hd square tube table with 90" wide push frame, and 3-1/2" round pivot bushing
- 4 (2) Telescopic trip bars, (6) extension trip springs and (4) 3" poly bushings for return trip cushions
- 5 (5) Moldboard hook-up points with 1/2" reinforced ribs, 3" bearing surface and 1-1/4" pins
- 6 Extended moldboard continuously welded
- 7 7" X 4" x 1/2" fully boxed bottom angle

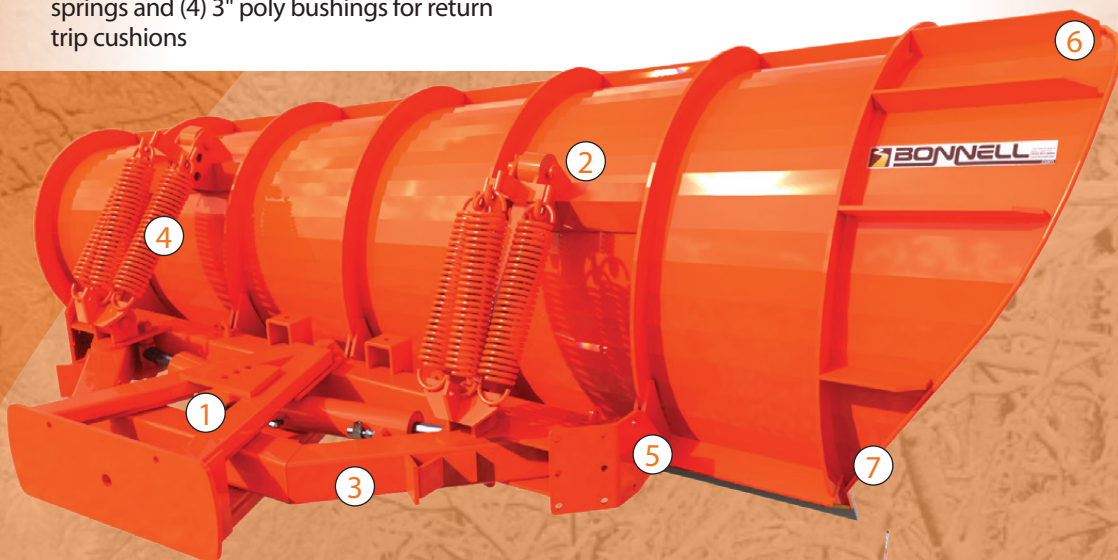

STAINLESS STEEL TAPERED MOLDBOARD OPTION

HIGH COUNTRY PLOW OPTIONS

Plow Lift Options

- Chain
Level Raise Lift System
Chain And Saddle
Cable Wrap

Plow Hook-Up Options

- Quick Attach Loop
Swivel Bar With Push Ears
(1- 1/4" Pins @ 30.5")
Husting Style
QL2, UQH, or Other

Moldboard Options

- 3/4" Bottom Angle
7- Gauge Steel Construction
Curb Cut (Mailbox Cut)
Extra Ribs
UHMW Poly Construction

Table Options

- Extended Push Frame
- Manual Reverse
- Fixed Table

Running Gear Options

- Standard Mushroom Shoes
- Heavy-Duty Mushroom Shoes
- Heavy-Duty Even Wear Shoes
- Carbide Even Wear Shoes
- 10" Steel Caster Wheels
- 5.70" x 8" Pneumatic Tires
- 4 Foam-Filled Rubber Tires
Don't use with Cable Wrap Lift Assemblies

Cutting Edge Options

- High Carbon Steel
- Rubber
- UHMW Poly
- Carbide Insert with Cover Blade
- Flame Hardened
- 5 PolarFlex Systems
All cutting edges available in various sizes

Other Options

- Cushion Valve
- 6 Curb Shoes
Blade Savers- Carbide
Blade Guides
- 7 Rubber Snow Deflector
Plow Stand
Extra Extension Trip Springs

Tripping Options

- 8 Extension Trip Moldboard
- Compression Trip Moldboard
- Dual Moldboard & Trip Edge
- Torsion Trip Cutting Edge
- Slotted Trip

Paint Options

- Special Paint Available

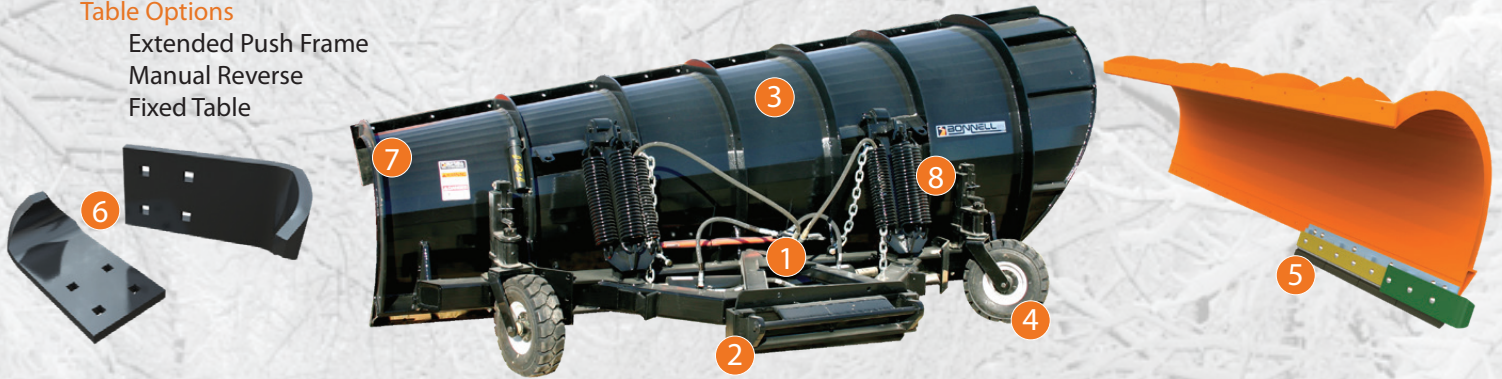

HIGH COUNTRY TAPERED PLOW STANDARD SPECIFICATIONS

MODEL NUMBER	OVERALL LENGTH	END & END HEIGHT	CUTTING SWATH @ 35°	APPROX. WEIGHT OF BASE UNIT	NUMBER OF SPRINGS
10TA2848MX1	11'	28" to 48"	8'2"	2069 lbs.	6
11TA2749MX1	12'	27" to 49"	9'	2136 lbs.	6
12TA2650MX1	13'	26" to 50"	9' 9"	2123 lbs.	6
10TA3252MX1	12'	32" to 52"	8' 2"	2109 lbs.	6
11TA3153MX1	13'	31" to 53"	9'	2179 lbs.	6
12TA3054MX1	14'	30" to 54"	9' 9"	2258 lbs.	6
10TA3861MX1	12'	39" to 60"	8' 2"	2192 lbs.	6
11TA3861MX1	13'	38" to 61"	9'	2267 lbs.	6
12TA3762MX1	14'	37" to 62"	9' 9"	2351 lbs.	6
12TA4272MX1	14'	42" to 72"	9' 9"	2551 lbs.	6

- Moldboard Thickness: 10 Gauge
- Moldboard Reinforcing: (7) - 1/2" x 3" Ribs
- Adjustable Moldboard Pitch Setting: 35°, 25° or 15° off vertical
- Lower Reinforcing Angle: 7" x 4" x 1/2"
- Reversing Frame: 5" x 3/8" Wall Front Push Tube
- Reversing Cylinders: 4" Bore x 12" Stroke (2" Rod) Double Acting
- Reversing Limits (left & right): 0 to 35 degrees
- Plow to Table Hinge Points: (5) 1-1/4" Hinge Pins, Spanning 90°
- Cutting Edge: 5/8" x 6" High Carbon Steel
- Pivot Pin: 1-1/2" Grade 8 Bolt
- Cylinder Pins: 1-1/4" C1045 Steel Pins

Call factory for complete specifications and optional equipment not listed. Weights do not include optional equipment.



www.bonnell.com • (800) 851-9664 • info@bonnell.com
1385 Franklin Grove Rd. • Dixon, IL 61021



AUTHORIZED DEALER:

HIGH COUNTRY EXPRESSWAY PLOW

SNOW & ICE CONTROL

FEATURES & BENEFITS:

- 1 Deep "C" A-Frame
- 2 (3) Adjustable pitch settings
- 3 5" X 5" x 3/8" hd square tube table with 90" wide push frame, and 3-1/2" round pivot bushing
- 4 (2) Telescopic trip bars, (6) extension trip springs or (2) compression (shown) and (4) 3" poly bushings for return trip cushions
- 5 (5) Moldboard hook-up points with 1/2" reinforced ribs, 3" bearing surface and 1-1/4" pins
- 6 Extended moldboard continuously welded
- 7 7" X 4" x 1/2" fully boxed bottom angle



HIGH COUNTRY PLOW OPTIONS

Plow Lift Options

Chain

- 1 Level Raise Lift System
- Chain And Saddle
- Cable Wrap

Plow Hook-Up Options

- 2 Quick Attach Loop
- Swivel Bar With Push Ears
(1- 1/4" Pins @ 30.5")
- Husting Style
- QL2, UQH, or Other

Moldboard Options

- 3/4" Bottom Angle
- 3 7- Gauge Steel Construction
- Curb Cut (Mailbox Cut)
- Extra Ribs
- UHMW Poly Construction

Table Options

- Extended Push Frame
- Manual Reverse

Running Gear Options

- Standard Mushroom Shoes
- Heavy-Duty Mushroom Shoes
- 4 Heavy-Duty Even Wear Shoes
- Carbide Even Wear Shoes
- 10" Steel Caster Wheels
- 5.70" x 8" Pneumatic Tires
- Foam-Filled Rubber Tires
- Don't use with Cable Wrap Lift Assemblies

Cutting Edge Options

- High Carbon Steel
- Rubber
- UHMW Poly
- Carbide Insert with Cover Blade
- Flame Hardened
- 5 PolarFlex Systems
- All cutting edges available in various sizes

Other Options

- 6 Cushion Valve
- Curb Shoes

Blade Savers- Carbide

Blade Guides

- 7 Rubber Snow Deflector
- Plow Stand
- Extra Extension Trip Springs

Tripping Options

- Extension Trip Moldboard
- Compression Trip Moldboard
- Dual Moldboard & Trip Edge
- 8 Torsion Trip Cutting Edge
- Slotted Trip

Paint Options

Special Paint Available



HIGH COUNTRY EXPRESSWAY PLOW STANDARD SPECIFICATIONS

MODEL NUMBER	OVERALL LENGTH	END HEIGHT	CUTTING SWATH @ 35°	APPROX. WEIGHT OF BASE UNIT	NUMBER OF SPRINGS
10EW3648MX1	13' 8"	48"	8'2"	2290 lbs.	6
11EW3649MX1	14' 8"	49"	9'	2367 lbs.	6
12EW3650MX1	15' 8"	50"	9' 9"	2454 lbs.	6
10EW4052MX1	13' 8"	52"	8' 2"	2360 lbs.	6
11EW4053MX1	14' 8"	53"	9'	2440 lbs.	6
12EW4054MX1	15' 8"	54"	9' 9"	2529 lbs.	6
10EW4760MX1	13' 8"	60"	8' 2"	2480 lbs.	6
11EW4761MX1	14' 8"	61"	9'	2558 lbs.	6
12EW4762MX1	15' 8"	62"	9' 9"	2652 lbs	6

- Moldboard Thickness: 10 Gauge
- Moldboard Reinforcing: (7) - 1/2" x 3" Ribs
- Adjustable Moldboard Pitch Setting: 35°, 25° or 15° off vertical
- Lower Reinforcing Angle: 7" x 4" x 1/2"
- Reversing Frame: 5" x 3/8" Wall Front Push Tube
- Reversing Cylinders: 4" Bore x 12" Stroke (2" Rod) Double Acting
- Reversing Limits (left & right): 0 to 35 degrees
- Plow to Table Hinge Points: (5) 1-1/4" Hinge Pins, Spanning 90°
- Cutting Edge: 5/8" x 6" High Carbon Steel
- Pivot Pin: 1-1/2" Grade 8 Bolt
- Cylinder Pins: 1-1/4" C1045 Steel Pins

Call factory for complete specifications and optional equipment not listed. Weights do not include optional equipment.



www.bonnell.com • (800) 851-9664 • info@bonnell.com
1385 Franklin Grove Rd. • Dixon, IL 61021



AUTHORIZED DEALER:

HIGH COUNTRY DISTANT DISCHARGE PLOW

SNOW & ICE CONTROL

FEATURES & BENEFITS:

- 1 Deep "C" A-Frame
- 2 (3) Adjustable pitch settings
- 3 5" X 5" x 3/8" hd square tube table with 90" wide push frame, and 3-1/2" round pivot bushing
- 4 (2) Telescopic trip bars, (6) extension trip springs and (4) 3" poly bushings for return trip cushions
- 5 (5) Moldboard hook-up points with 1/2" reinforced ribs, 3" bearing surface and 1-1/4" pins
- 6 Extended moldboard continuously welded
- 7 7" X 4" x 1/2" fully boxed bottom angle
- 8 Vertical ribs on ears to reduce vibration and cracking

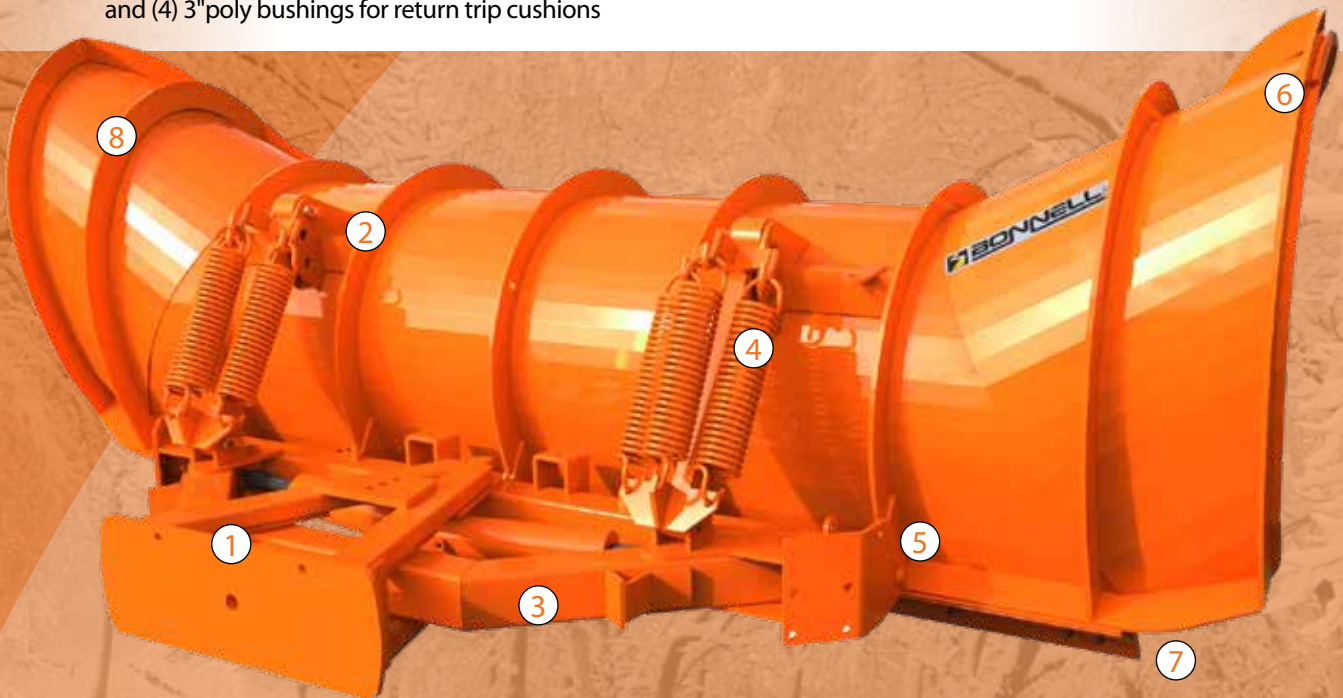

HIGH COUNTRY PLOW OPTIONS

Plow Lift Options

- Chain
- Level Raise Lift System
- Chain And Saddle
- Cable Wrap

Plow Hook-Up Options

- Quick Attach Loop
- Swivel Bar With Push Ears (1- 1/4" Pins @ 30.5")
- Husting Style

- 1 Parallel Lift
QL2, UQH, or Other

Moldboard Options

- 2 3/4" Bottom Angle
- 2 7- Gauge Steel Construction
Curb Cut (Mailbox Cut)
Extra Ribs
UHMW Poly Construction

Table Options

- Extended Push Frame
- Manual Reverse

Running Gear Options

- Standard Mushroom Shoes
- Heavy-Duty Mushroom Shoes
- Heavy-Duty Even Wear Shoes
- Carbide Even Wear Shoes
- 10" Steel Caster Wheels
- 5.70" x 8" Pneumatic Tires
- Foam-Filled Rubber Tires
- 3 Sno-Wheel Systems
Don't use with Cable Wrap Lift Assemblies

Cutting Edge Options

- 4 High Carbon Steel
Rubber
UHMW Poly
Carbide Insert with Cover Blade
Flame Hardened
- 5 PolarFlex Systems
All cutting edges available in various sizes

Other Options

- Cushion Valve
- 6 Curb Shoes
- Blade Savers- Carbide
- Blade Guides
- Rubber Snow Deflector
- Plow Stand
- Extra Extension Trip Springs

Tripping Options

- 7 Extension Trip Moldboard
- 7 Compression Trip Moldboard
- 7 Dual Moldboard & Trip Edge
- 7 Torsion Trip Cutting Edge
- 7 Slotted Trip

Paint Options

- Special Paint Available



HIGH COUNTRY DISTANT DISCHARGE PLOW STANDARD SPECIFICATIONS

MODEL NUMBER	OVERALL LENGTH	EAR HEIGHT	CUTTING SWATH @ 35°	APPROX. WEIGHT OF BASE UNIT	NUMBER OF SPRINGS
10DD42MX1	12'	58"	8'2"	2269 lbs.	6
11DD42MX1	13'	58"	9'	2330 lbs.	6
12DD42MX1	14'	58"	9' 9"	2391 lbs.	6
10DD49MX1	12' 4"	68"	8' 2"	2346 lbs.	6
11DD49MX1	13' 4"	68"	9'	2436 lbs.	6
12DD49MX1	14' 4"	68"	9' 9"	2526 lbs.	6
14DD49MX1	16' 4"	68"	11' 6"	2669 lbs.	6
11DD60MX1	14' 1"	81"	9'	2890 lbs.	6
12DD60MX1	15' 1"	81"	9' 9"	2980 lbs.	6
14DD60MX1	17' 1"	81"	11' 6"	3160 lbs.	6

- Moldboard Thickness: 10 Gauge
- Moldboard Reinforcing: (7) - 1/2" x 3" Ribs
- Adjustable Moldboard Pitch Setting: 35°, 25° or 15° off vertical
- Lower Reinforcing Angle: 7" x 4" x 1/2"
- Reversing Frame: 5" x 3/8" Wall Front Push Tube
- Reversing Cylinders: 4" Bore x 12" Stroke (2" Rod) Double Acting
- Reversing Limits (left & right): 0 to 35 degrees
- Plow to Table Hinge Points: (5) 1-1/4" Hinge Pins, Spanning 90°
- Cutting Edge: 5/8" x 6" High Carbon Steel
- Pivot Pin: 1-1/2" Grade 8 Bolt
- Cylinder Pins: 1-1/4" C1045 Steel Pins

Call factory for complete specifications and optional equipment not listed. Weights do not include optional equipment.



www.bonnell.com • (800) 851-9664 • info@bonnell.com
1385 Franklin Grove Rd. • Dixon, IL 61021



AUTHORIZED DEALER:

HIGH COUNTRY TORSION TRIP EDGE PLOW

SNOW & ICE CONTROL

FEATURES & BENEFITS:

- 1 Deep "C" A-Frame
- 2 (2) Adjustable pitch settings
- 3 5" X 5" x 3/8" hd square tube table with 90" wide push frame, and 3-1/2" round pivot bushing
- 4 (2) 1" X 2-1/2" trip connecting posts - fastened by 1-1/4" bolts
- 5 (5) Moldboard hook-up points with 1/2" reinforced ribs, 3" bearing surface and 1-1/4" pins
- 6 (4) 3/4" Diameter spring wire torsion - trip springs - independently replaceable, 7/8" optional
- 7 Extended moldboard continuously welded



HIGH COUNTRY TORSION TRIP EDGE PLOW OPTIONS

Plow Lift Options

Chain

- 1 Level Raise Lift System
- Chain And Saddle
- Cable Wrap

Plow Hook-Up Options

Quick Attach Loop
Swivel Bar With Push Ears
(1- 1/4" Pins @ 30.5")

- 2 Husting Style
- QL2, UQH, or Other

Moldboard Options

7- Gauge Steel Construction
Curb Cut (Mailbox Cut)
Extra Ribs

- 3 UHMW Poly Construction
- Special sizes available

Table Options

Extended Push Frame
Manual Reverse

Running Gear Options

Standard Mushroom Shoes
Heavy-Duty Mushroom Shoes
Heavy-Duty Even Wear Shoes
Carbide Even Wear Shoes

- 4 10" Steel Caster Wheels
- 5 5.70" x 8" Pneumatic Tires
- Foam-Filled Rubber Tires
- Don't use with Cable Wrap Lift Assemblies

Cutting Edge Options

High Carbon Steel
Rubber
UHMW Poly
Carbide Insert with Cover Blade
Flame Hardened
PolarFlex Systems
Edges available in various sizes

Other Options

Cushion Valve
Curb Shoes
Blade Savers- Carbide
Blade Guides
Rubber Snow Deflector
Plow Stand

Tripping Options

- 6 2, 3 or 4 Section Trip Edge

Paint Options

Special Paint Available

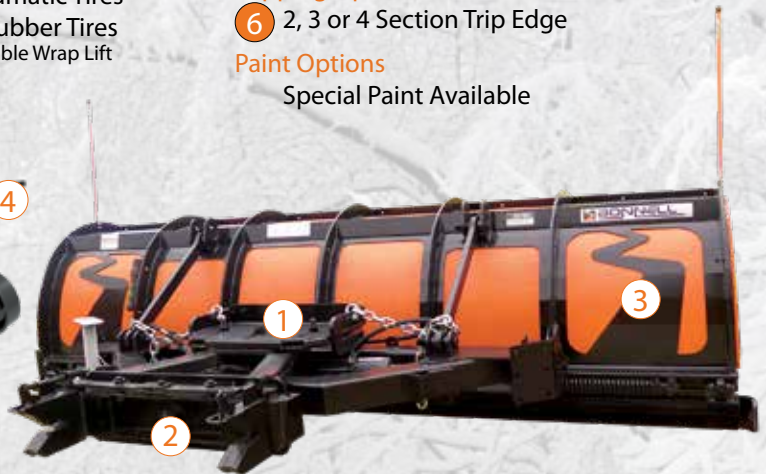

HIGH COUNTRY TORSION TRIP EDGE PLOW STANDARD SPECIFICATIONS

MODEL NUMBER	OVERALL LENGTH	OVERALL HEIGHT	CUTTING SWATH @ 35°	APPROX. WEIGHT OF BASE UNIT	NUMBER OF SPRINGS
10ST36TT1	10'	36"	8'2"	2050 lbs.	4
11ST36TT1	11'	36"	9'	2115 lbs.	4
12ST36TT1	12'	36"	9'9"	2180 lbs.	4
10ST42TT1	10'	42"	8'2"	2142 lbs.	4
11ST42TT1	11'	42"	9'	2209 lbs.	4
12ST42TT1	12'	42"	9'9"	2276 lbs.	4
10ST49TT1	10'	49"	9'	2190 lbs.	4
11ST49TT1	11'	49"	9'9"	2260 lbs.	4
12ST49TT1	12'	49"	11'6"	2330 lbs	4

- Spring Wire Diameter: 3/4" (7/8" option)
- Adjustable Moldboard Pitch Setting: 15° or 5° off vertical
- Lower Reinforcing Angle: 4" x 4" x 1/2"
- Trip Angle: 4" x 4" x 1/2" reinforced with 1/2" plate gussets
- Trip Pin Diameter: 1-1/4"

Call factory for complete specifications and optional equipment not listed. Weights do not include optional equipment.



AUTHORIZED DEALER:

www.bonnell.com • (800) 851-9664 • info@bonnell.com
1385 Franklin Grove Rd. • Dixon, IL 61021



HIGH COUNTRY ALASKA PLOW

SNOW & ICE CONTROL

FEATURES & BENEFITS:

- 1 Deep "C" A-Frame
- 2 (3) Adjustable pitch settings
- 3 5" X 5" x 3/8" hd square tube table with 90" wide push frame, and 3-1/2" round pivot bushing
- 4 (2) Telescopic trip bars, (6) extension trip springs and (4) 3" poly bushings for return trip cushions
- 5 (5) Moldboard hook-up points with 1/2" reinforced ribs, 3" bearing surface and 1-1/4" pins
- 6 Extended moldboard continuously welded
- 7 7" X 4" x 1/2" fully boxed bottom angle



HIGH COUNTRY ALASKA PLOW OPTIONS

Plow Lift Options

- 1 Chain
 - Level Raise Lift System
 - Chain And Saddle
 - Cable Wrap

Plow Hook-Up Options

- 2 Quick Attach Loop
- 2 Swivel Bar With Push Ears
 - (1- 1/4" Pins @ 30.5")
 - Husting Style
 - QL2, UQH, or Other

Moldboard Options

- 3/4" Bottom Angle
- 3 7- Gauge Steel Construction
 - Curb Cut (Mailbox Cut)
 - Extra Ribs
 - UHMW Poly Construction

Table Options

- Extended Push Frame
- Manual Reverse

Running Gear Options

- Standard Mushroom Shoes
- Heavy-Duty Mushroom Shoes
- Heavy-Duty Even Wear Shoes
- Carbide Even Wear Shoes
- 10" Steel Caster Wheels
- 5.70" x 8" Pneumatic Tires
- Foam-Filled Rubber Tires
- Don't use with Cable Wrap Lift Assemblies

Cutting Edge Options

- High Carbon Steel
- Rubber
- UHMW Poly
- Carbide Insert with Cover Blade
- Flame Hardened
- 4 PolarFlex Systems
 - All cutting edges available in various sizes

Other Options

- Cushion Valve
- 5 Curb Shoes
- Blade Savers- Carbide
- Blade Guides
- Rubber Snow Deflector
- Plow Stand
- 7 Extra Extension Trip Springs

Tripping Options

- Extension Trip Moldboard
- Compression Trip Moldboard
- Dual Moldboard & Trip Edge
- Torsion Trip Cutting Edge
- Slotted Trip

Paint Options

- Special Paint Available



HIGH COUNTRY ALASKA PLOW STANDARD SPECIFICATIONS

MODEL NUMBER	OVERALL LENGTH	STRAIGHT HEIGHT	HEIGHT AT DISCHARGE END	APPROX. WEIGHT OF BASE UNIT	NUMBER OF SPRINGS
10AK3648MX1	11'	36"	48"	2087 lbs.	6
11AK3649MX1	12'	36"	49"	2148 lbs.	6
12AK3650MX1	13'	36"	50"	2208 lbs.	6
10AK4252MX1	10'	42"	52"	2128 lbs.	6
11AK4253MX1	12'	42"	53"	2197 lbs.	6
12AK4254MX1	13'	42"	54"	2253 lbs.	6
11AK4960MX1	12'	49"	61"	2305 lbs.	8
12AK4961MX1	13'	49"	62"	2372 lbs.	8
12AK4962MX1	13'	49"	75"	3001 lbs	10

- Moldboard Thickness: 10 Gauge
- Moldboard Reinforcing: (7) - 1/2" x 3" Ribs
- Adjustable Moldboard Pitch Setting: 35°, 25° or 15° off vertical
- Lower Reinforcing Angle: 7" x 4" x 1/2"
- Reversing Frame: 5" x 3/8" Wall Front Push Tube
- Reversing Cylinders: 4" Bore x 12" Stroke (2" Rod) Double Acting
- Reversing Limits (left & right): 0 to 35 degrees
- Plow to Table Hinge Points: (5) 1-1/4" Hinge Pins, Spanning 90°
- Cutting Edge: 5/8" x 6" High Carbon Steel
- Pivot Pin: 1-1/2" Grade 8 Bolt
- Cylinder Pins: 1-1/4" C1045 Steel Pins



www.bonnell.com • (800) 851-9664 • info@bonnell.com
1385 Franklin Grove Rd. • Dixon, IL 61021



CERTIFIED BONNELL DEALER:

METROPOLITAN STRAIGHT PLOW

SNOW & ICE CONTROL

FEATURES & BENEFITS:

- ① (3) Adjustable pitch settings
- ② 4" X 4" x 3/8" tube push frame spanning 90"
- ③ (2) Compression trip bars, with 3" rubber bushings top & bottom for return trip cushion
- ④ (5) Moldboard hook-up points with 1/2" reinforced ribs, 3" bearing surface and 1-1/4" pins
- ⑤ 7" X 4" x 1/2" fully boxed bottom angle
- ⑥ Extended moldboard continuously welded

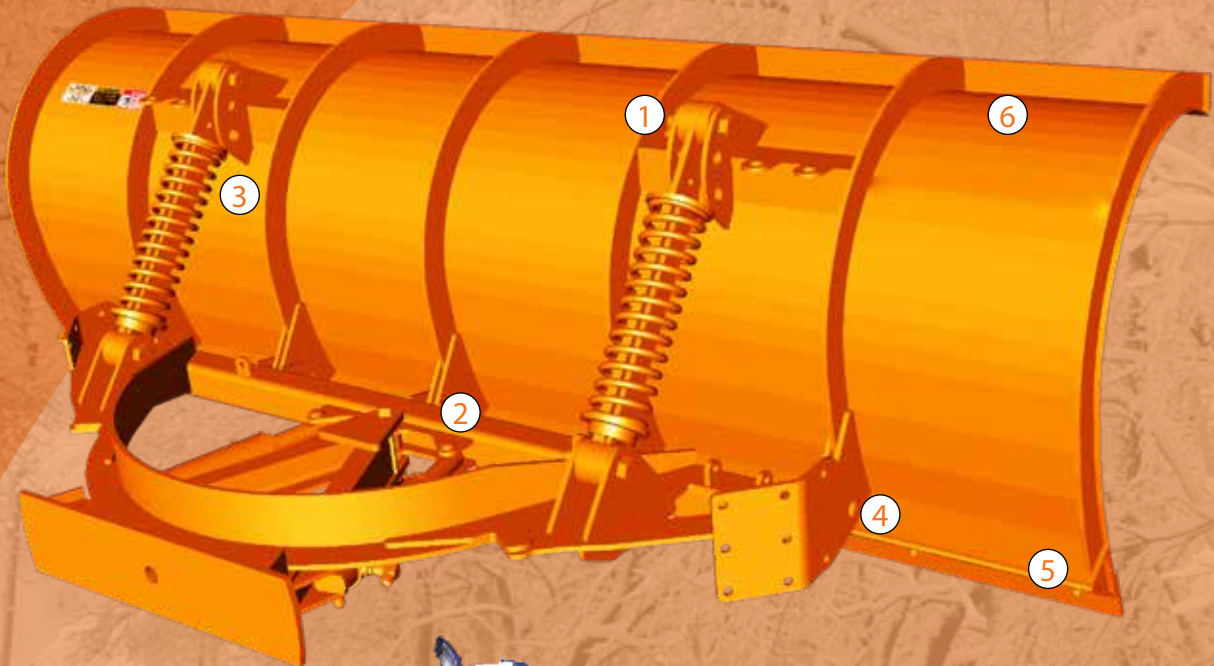

METROPOLITAN PLOW OPTIONS

Plow Lift Options

- Chain
- Level Raise Lift System
- Chain And Saddle
- Cable Wrap

Plow Hook-Up Options

- Quick Attach Loop
- Swivel Bar With Push Ears
(1- 1/4" Pins @ 30.5")
- Husting Style
- Custom Application

Moldboard Options

- 3/4" Bottom Angle
- 1** 7- Gauge Steel Construction
- Curb Cut (Mailbox Cut)
- Extra Ribs
- UHMW Poly Construction

Table Options

- Extended Push Frame
- Manual Reverse

Running Gear Options

- Standard Mushroom Shoes
- Heavy-Duty Mushroom Shoes
- Heavy-Duty Even Wear Shoes
- Carbide Even Wear Shoes
- 10" Steel Caster Wheels
- 5.70" x 8" Pneumatic Tires
- Foam-Filled Rubber Tires
- Don't use with Cable Wrap Lift Assemblies

Cutting Edge Options

- High Carbon Steel
- Rubber
- UHMW Poly
- Carbide Insert with Cover Blade
- Flame Hardened
- 2** PolarFlex Systems
- All cutting edges available in various sizes

Other Options

- Cushion Valve
- 3** Curb Shoes
- Blade Savers- Carbide
- Blade Guides
- Rubber Snow Deflector
- Plow Stand
- Extra Extension Trip Springs

Tripping Options

- Extension Trip Moldboard
- Compression Trip Moldboard
- Dual Moldboard & Trip Edge
- Torsion Trip Cutting Edge
- Slotted Trip

Paint Options

- Special Paint Available



METROPOLITAN STRAIGHT PLOW STANDARD SPECIFICATIONS

MODEL NUMBER	OVERALL LENGTH	MOLDBOARD HEIGHT	CUTTING SWATH @ 35°	APPROX. WEIGHT OF BASE UNIT	NUMBER OF SPRINGS
10ST36MC7	10'	36"	8'2"	2050 lbs.	2
11ST36MC7	11'	36"	9'	2115 lbs.	2
12ST36MC7	12'	36"	9' 10"	2180 lbs.	2
10ST42MC7	10'	42"	8' 2"	2142 lbs.	2
11ST42MC7	11'	42"	9'	2209 lbs.	2
12STM2MC7	12'	42"	9' 10"	2276 lbs.	2
10ST49MC7	10'	49"	8' 2"	2190 lbs.	2
11ST49MC7	11'	49"	9'	2260 lbs.	2
12ST49MC7	12'	49"	9' 10"	2330 lbs.	2

- Moldboard Thickness: 10 Gauge
- Moldboard Reinforcing: (7) - 1/2" x 3" Ribs
- Adjustable Moldboard Pitch Setting: 25°, 15° or 5° off vertical
- Lower Reinforcing Angle: 7" x 4" x 1/2"
- Reversing Frame: 5' x 3- 1/2" x 1/2" Angle Iron Sector
- Reversing Cylinders: Chrome 3" Bore x 10" Stroke (2" Rod) Double Acting
- Reversing Limits (left & right): 0 to 35 with Positive Stops
- Plow to Table Hinge Points: (5) 1-1/4" Hinge Pins, Spanning 90"
- Cutting Edge: 5/8" x 6" High Carbon Steel
- Pivot Pin: 1-1/4" Grade 8 Bolt
- Cylinder Pins: 1" C1045 Steel Pins

Call factory for complete specifications and optional equipment not listed. Weights do not include optional equipment.



www.bonnell.com • (800) 851-9664 • info@bonnell.com
1385 Franklin Grove Rd. • Dixon, IL 61021



AUTHORIZED DEALER:

METROPOLITAN TORSION TRIP PLOW

SNOW & ICE CONTROL

FEATURES & BENEFITS:

- ① (2) Adjustable pitch settings
- ② 4" X 4" x 3/8" tube push frame spanning 90"
- ③ (2) 1" X 2-1/2" trip connecting post fastened by 1-1/4" pins
- ④ (5) Moldboard hook-up points with 1/2" reinforced ribs at hook up point, 3" bearing surface and 1-1/4" pins
- ⑤ (4) 3/4" Diameter spring wire torsion-trip springs - independently replaceable, 7/8" optional
- ⑥ Extended moldboard continuously welded



METROPOLITAN TORSION TRIP EDGE PLOW OPTIONS

Plow Lift Options

- Chain
- 1 Level Raise Lift System
- Chain And Saddle
- Cable Wrap

Plow Hook-Up Options

- Quick Attach Loop
- 2 Swivel Bar With Push Ears
- (1- 1/4" Pins @ 30.5")
- Husting Style
- QL2, UQH, or Other

Moldboard Options

- 3 7- Gauge Steel Construction
- Curb Cut (Mailbox Cut)
- Extra Ribs
- UHMW Poly Construction
- Special sizes available

Table Options

- Extended Push Frame
- Manual Reverse

Running Gear Options

- Standard Mushroom Shoes
- Heavy-Duty Mushroom Shoes
- Heavy-Duty Even Wear Shoes
- Carbide Even Wear Shoes
- 4 10" Steel Caster Wheels
- 5.70" x 8" Pneumatic Tires
- 5 Foam-Filled Rubber Tires
- Don't use with Cable Wrap Lift Assemblies

Cutting Edge Options

- High Carbon Steel
- Rubber
- UHMW Poly

- Carbide Insert with Cover Blade
- Flame Hardened
- PolarFlex Systems
- Edges available in various sizes

Other Options

- Cushion Valve
- 6 Curb Shoes
- Blade Savers- Carbide
- Blade Guides
- Rubber Snow Deflector
- Plow Stand

Tripping Options

- 2, 3 or 4 Section Trip Edge

Paint Options

- 7 Special Paint Available

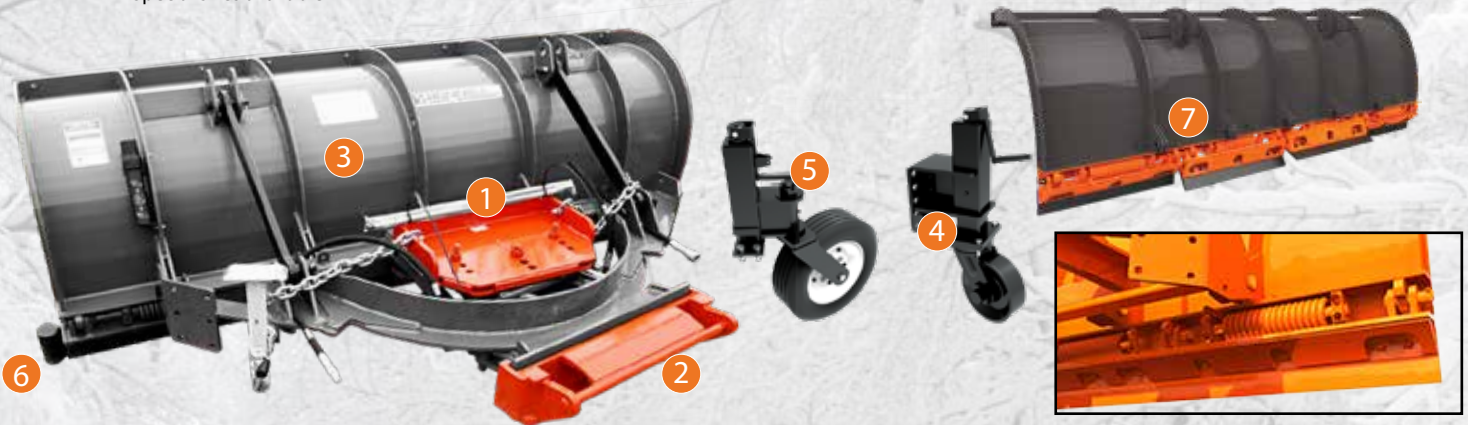

METROPOLITAN TORSION TRIP EDGE STRAIGHT PLOW STANDARD SPECIFICATIONS

MODEL NUMBER	OVERALL LENGTH	OVERALL HEIGHT	CUTTING SWATH @ 35°	APPROX. WEIGHT OF BASE UNIT	NUMBER OF SPRINGS
10ST36TT7	10'	36"	8'2"	1765 lbs.	4
11ST36TT7	11'	36"	9'	1815 lbs.	4
12ST36TT7	12'	36"	9' 10"	1885 lbs.	4
10ST42TT7	10'	42"	8' 2"	1865 lbs.	4
11ST42TT7	11'	42"	9'	1915 lbs.	4
12ST42TT7	12'	42"	9' 10"	1985 lbs.	4
10ST49TT7	10'	49"	8' 2"	1905 lbs.	4
11ST49TT7	11'	49"	9' 0"	1975 lbs.	4
12ST49TT7	12'	49"	9' 10"	2045 lbs	4

- Moldboard Thickness: 10 Gauge
- Moldboard Reinforcing: (7) - 1/2" x 3" Ribs
- Adjustable Moldboard Pitch Setting: 25°, 15° or 5° off vertical
- Lower Reinforcing Angle: 7" x 4" x 1/2" Fully boxed with 3/8" x 6-3/4" Plate
- Reversing Frame: 5' x 3- 1/2" x 1/2" Angle Iron Sector
- Reversing Cylinders: Chrome 3" Bore x 10" Stroke (2" Rod) Double Acting
- Reversing Limits (left & right): 0 to 35 with Positive Stops
- Plow to Table Hinge Points: (5) 1-1/4" Hinge Pins, Spanning 90"
- Cutting Edge: 5/8" x 6" High Carbon Steel
- Pivot Pin: 1-1/4" Grade 8 Bolt
- Cylinder Pins: 1" C1045 Steel Pins

Call factory for complete specifications and optional equipment not listed. Weights do not include optional equipment.



www.bonnell.com • (800) 851-9664 • info@bonnell.com
1385 Franklin Grove Rd. • Dixon, IL 61021



AUTHORIZED DEALER:

SLOTTED TRIP TAPERED PLOW

SNOW & ICE CONTROL

FEATURES & BENEFITS:

- 1 Heavy duty fixed one way tubular push frame
- 2 (3) Adjustable pitch settings
- 3 Heavy duty adjustable compression spring trip assembly
- 4 Slotted trip design lifts plow up and back to clear obstructions
- 5 (5) Table to moldboard hook-up points with 1/2" reinforced ribs, 3" bearing surface and 1-1/4" pins
- 6 7" X 4" x 1/2" fully boxed bottom angle
- 7 Extended roll moldboard continuously welded



SLOTTED TRIP TAPERED PLOW OPTIONS

Plow Lift Options

- Chain
Chain And Saddle
Cable Wrap

Plow Hook-Up Options

- Quick Attach Loop
- Swivel Bar With Push Ears with (1- 1/4" Pins @ 30.5")
- Husting Style

- QL2, UQH, or Other

Moldboard Options

- 3/4" Bottom Angle
- 7 Gauge Steel Construction
- Land Slide
- Extra Ribs

Table Options

- Extended Push Frame
- Manual Reverse

Cutting Edge Options (Required)

- High Carbon Steel
- Rubber
- UHMW Poly
- Carbide Insert with Cover Blade
- Flame Hardened

- Polar-Flex Systems
All cutting edges available in various sizes

Other Options

- Curb Shoes
Blade Savers- Carbide
Blade Guides
Rubber Snow Deflector
Plow Stand

Paint Options

- Special Paint Available

Running Gear (Required)

- Standard Mushroom Shoes
- Heavy-Duty Mushroom Shoes
- Heavy-Duty Even Wear Shoes
- Carbide Even Wear Shoes

- 10" Steel Caster Wheels
- 5.70" x 8" Pneumatic Tires
- Foam-filled Rubber Tires

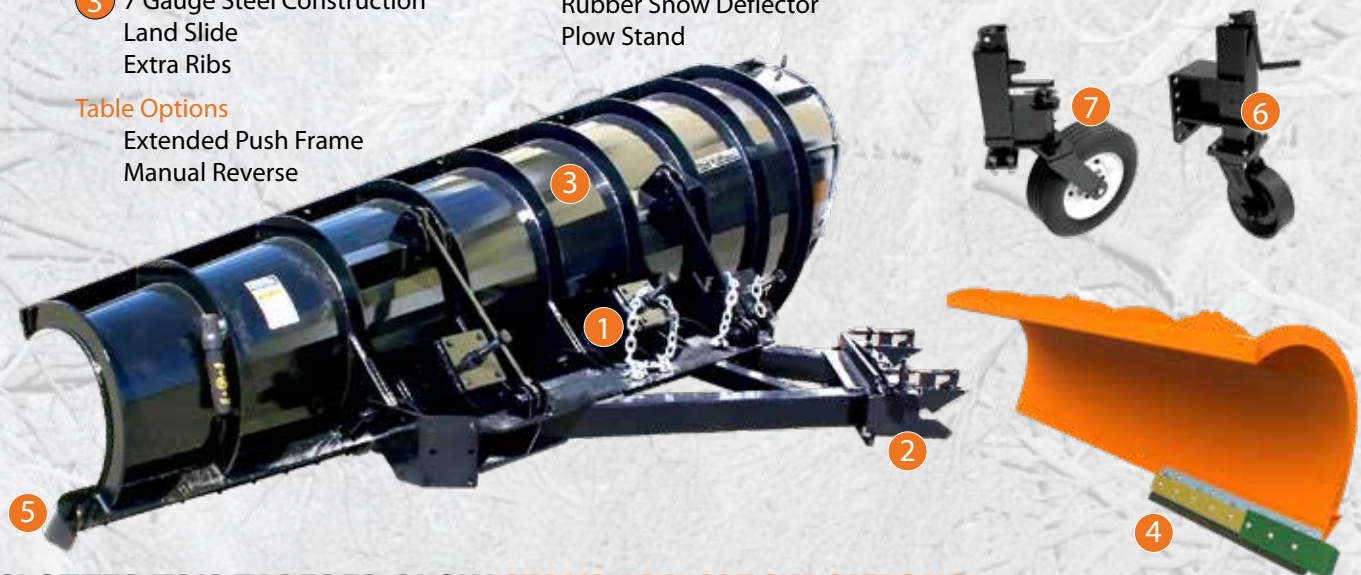

SLOTTED TRIP TAPERED PLOW STANDARD SPECIFICATIONS

MODEL NUMBER	OVERALL LENGTH	MOLDBOARD HEIGHT	CUTTING SWATH @ 35°	APPROX. WEIGHT OF BASE UNIT	NUMBER OF SPRINGS
10TA2848MS5	11'	48"	8'2"	2069 lbs.	3
11TA2749MS5	12'	49"	9'	2136 lbs.	3
12TA2650MS5	13'	50"	9'9"	2213 lbs.	3
10TA3252MS5	12'	52"	8'2"	2109 lbs.	3
11TA3153MS5	13'	53"	9'	2179 lbs.	3
12TA3054MS5	14'	54"	9'9"	2258 lbs.	3
14TA3960MS5	12'	60"	8'2"	2192 lbs.	3
11TA3861MS5	13'	61"	9'	2267 lbs.	3
12TA3762MS5	14'	62"	9'9"	2351 lbs.	3
12TA4272MS5	14'	72"	9'9"	2551 lbs.	3

- Moldboard Thickness: 10 Gauge
- Moldboard Reinforcing: (7) - 1/2" x 3" Ribs
- Adjustable Moldboard Pitch Setting: 35°, 25°, 15° off vertical
- Lower Reinforcing Angle: 7" x 4" x 1/2"
- Plow Push Frame: 5" x 3/8" Wall Front Push Tube
- Plow to Table Hinge Points: (5) 1-1/4" Hinge Pins, Spanning 90°
- Cutting Edge: 5/8" x 6" High Carbon Steel Std. Punch
- Trip Springs: (3) 5-3/4" x 22" Long Compression
- Slot Length: 7"

Call factory for complete specifications and optional equipment not listed. Weights do not include optional equipment.



www.bonnell.com • (800) 851-9664 • info@bonnell.com
1385 Franklin Grove Rd. • Dixon, IL 61021



AUTHORIZED DEALER: